

Model 1800

Pressure Fryer

- **Proven round cooking well design** – engineered for more uniform heat distribution, durability, and efficiency; no cold spots or corners.
- **Unique Auto Comp™ feature** – automatically adjusts cooking time to accommodate for varying sizes and temperatures of loads.
- **Exclusive quick closing and opening single action sealing cover** – designed for safety and ease of use.
- **Built-in filter system** – provides quick, easy, and safe cooking oil filtration; no heated fittings to disconnect.
- **Automatic cook cycle counter** – monitors production between filtering.
- **Easy to operate** – one-of-a-kind Temp-N-Time™ feature offers the capability to pre-program up to 10 different cook cycles for quick and easy preparation of various menu items.
- **Compact** – occupies only 4.38 square feet of floor space.
- **Durable** – backed by a 5-year cooking well warranty and a 2-year solid state controller warranty.
- **Fast and productive** – cooks up to 40 pieces of fresh chicken per load in under 10 minutes!
- **Fits anywhere** – available in both gas and electric models.



CE approved machines available.

The only brand of equipment authorized for producing Genuine Broaster Chicken®!



Model 1800 Pressure Fryer

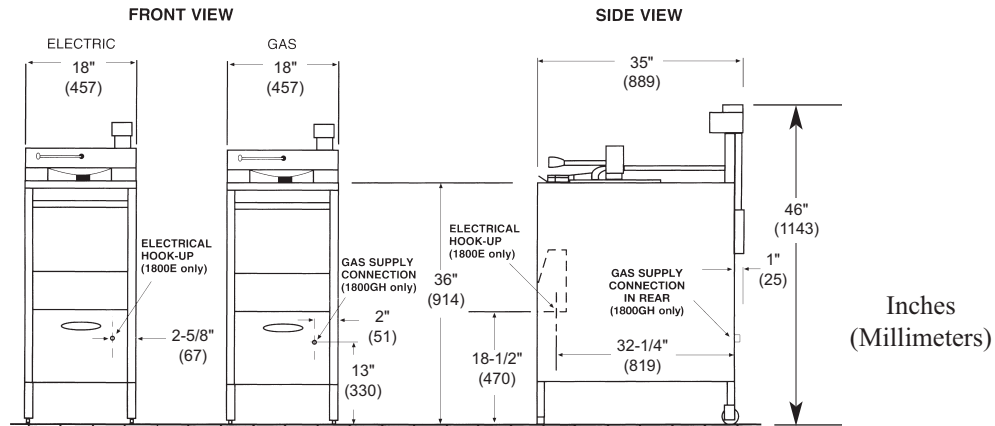

SPECIFICATIONS

MODEL	FRESH CHICKEN CAPACITY	COOKING OIL CAPACITY	OPERATING PRESSURE	OVERALL DIMENSIONS			COUNTER HEIGHT	SHIPPING WEIGHT	CUBES
				W	D	H			
1800E and 1800GH	14 lbs./load 80 lbs./hour	42 lbs.	12 - 14 P.S.I.	18" (457)	35" (1016)	46" (1200)	36" (914)	E: 270 lbs. GH: 310 lbs.	20.6

ENERGY REQUIREMENTS

1800E	Single Phase	208V - 48 Amps 240V - 45 Amps
	Three Phase	208V - 28 Amps 240V - 26 Amps
1800GH	65,000 BTU	120V - 15 Amps (6' cord & plug included)

Main Burner Orifice

Natural Gas: #24 Drill, LP Gas: #41 Drill

Note: Specifications indicated above are for elevations up to 2,000 feet. For higher elevations, consult your authorized Broaster distributor for proper orifice size.

Pilot Burner Orifice

Natural Gas: .018", LP Gas: .011"

Gas connection 1/2" NPT (adapter for 3/4" NPT included)

ADDITIONAL FEATURES

- Durable, welded tubular steel frame – powder coated to resist corrosion.
- Specially designed stainless steel basket with a three-position ratchet-style removable basket handle – for easier loading and unloading of product.
- Advanced solid state controls – for easy operation and dependability.
- Stainless steel top and side panels – for durability and easy cleaning.
- Rear casters (1800E unit only).

ACCESSORIES AVAILABLE

Basic Accessory Kit • Complete Start-up Accessory Kit • Caster Kit

